

**CHAPTER 12**

**PO 331 – DESCRIBE PRINCIPLES OF FLIGHT**





**ROYAL CANADIAN AIR CADETS**  
**PROFICIENCY LEVEL THREE**  
**INSTRUCTIONAL GUIDE**



**SECTION 1**

**EO M331.01 – DESCRIBE AIRCRAFT STABILITY**

---

Total Time: 60 min

---

**PREPARATION**

---

**PRE-LESSON INSTRUCTIONS**

Resources needed for the delivery of this lesson are listed in the lesson specification located in A-CR-CCP-803/PG-001, Chapter 4. Specific uses for said resources are identified throughout the instructional guide within the TP for which they are required.

Review the lesson content and become familiar with the material prior to delivering the lesson.

Set up the four stations as described in Annex A.

Create slide of Annex B.

**PRE-LESSON ASSIGNMENT**

N/A.

**APPROACH**

An in-class activity was chosen for TP 1 as it is an interactive way to introduce aircraft stability.

An interactive lecture was chosen for TPs 2–5 to review axes of rotation and introduce stability about the axes.

---

**INTRODUCTION**

---

**REVIEW**

N/A.

**OBJECTIVES**

By the end of this lesson the cadet shall have described aircraft stability.

**IMPORTANCE**

It is important for cadets to describe aircraft stability so that they understand why aircraft are designed with certain features. Cadets will also understand how an aircraft will react when flying through turbulent weather or when it is put through aggressive manoeuvres.

---

**Teaching Point 1**

**Demonstrate the Characteristics of Stability**

Time: 15 min

Method: In-Class Activity

---

**CHARACTERISTICS OF STABILITY**

**Stability.** The tendency of an aircraft in flight to remain in straight, level, upright flight and to return to this attitude, if displaced, without corrective action by the pilot.

**Static Stability.** The initial tendency of an aircraft to return to its original attitude, if displaced.

**Dynamic Stability.** The overall tendency of an aircraft to return to its original attitude.

**Positive Stability.** The aircraft is able to return to its original attitude without any corrective measure.

**Neutral Stability.** The aircraft will remain in the new attitude of flight after being displaced, neither returning to its original attitude, nor continuing to move away.

**Negative Stability.** The aircraft will continue moving away from its original attitude after being displaced.

---

**ACTIVITY**

Time: 10 min

---

**OBJECTIVE**

The objective of this activity is to provide a tactile method of illustrating the different types of aircraft stability.

**RESOURCES**

- Tennis ball,
- Three marbles,
- Table,
- Tape, and
- Two bowls.

**ACTIVITY LAYOUT**

Set up four stations IAW Annex A.

**ACTIVITY INSTRUCTIONS**

1. Divide the cadets into four groups of equal size.
2. Assign each group to a station.
3. Have each group perform the activity at each station.
4. After the cadets have been to all stations, ask the cadets what they observed.

**SAFETY**

N/A.

---

## CONFIRMATION OF TEACHING POINT 1

---

The cadets' participation in the stability activity will serve as confirmation of this TP.

---

### Teaching Point 2

### Review the Axes of an Aircraft

Time: 10 min

Method: Interactive Lecture

---

### AXES OF THE AIRCRAFT



Present the slide located at Annex B to the cadets.  
Demonstrate each axis with the model aircraft.

Each axis is an imaginary straight line which runs through the aircraft in a particular direction. All three axes intersect at the centre of gravity.



Ask the cadets what the three axes of an aircraft are.

#### Longitudinal Axis and Roll

This axis runs the length of the aircraft from the tip of the nose to the end of the empennage. Movement around this axis is roll.



Ask the cadets which control surface controls roll.

#### Lateral Axis and Pitch

This axis runs through the aircrafts' wings, from wing tip to wing tip. Movement around this axis is pitch.



Ask the cadets which control surface controls pitch.

#### Normal (Vertical) Axis and Yaw

This axis runs through the aircraft vertically top to bottom. Movement about this axis is yaw.

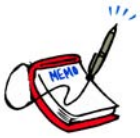

Ask the cadets which control surface controls yaw.



Have the cadets make a paper airplane, marking each of the axes. Have them hold their airplanes in the air while you call out a movement (eg, roll) which they will demonstrate individually using their airplanes.

---

### CONFIRMATION OF TEACHING POINT 2

---

The cadets' participation in the paper airplane activity will serve as the confirmation of this lesson.

---

### Teaching Point 3

### Explain Longitudinal Stability

Time: 10 min

Method: Interactive Lecture

---

### LONGITUDINAL STABILITY

Longitudinal stability is stability around the lateral axis and is known as pitch stability. To achieve longitudinal stability, aircraft are designed to be nose heavy if loaded correctly.

Two principle factors influence longitudinal stability:

- the horizontal stabilizer, and
- the centre of gravity.

#### The Effects of the Horizontal Stabilizer

The horizontal stabilizer is located at the tail end of the aircraft. Its function is similar to a counterweight at the end of a lever. When the nose of the aircraft is pushed up, this will force the tail down. Since the stabilizer now meets the airflow at a higher angle of attack, it will now produce more lift. This extra lift will counter the initial disturbance.



Use the model airplane to demonstrate the effects of the horizontal stabilizer.

#### The Effects of the Centre of Gravity

The centre of gravity is an important factor in aircraft stability. Every aircraft has a naturally occurring centre of gravity which is inherent in its design. As the aircraft is loaded, the position of the centre of gravity can change. If this change is drastic, it can have an adverse affect on the stability of an aircraft.



Use the model airplane to demonstrate a forward centre of gravity.

If the centre of gravity is too far forward, it will produce a nose-down tendency. This will force the pilot to use excessive back pressure on the controls to maintain normal flight. If left uncorrected, the aircraft will speed up and lose altitude.

If the centre of gravity is too far aft, it will produce a nose-up tendency. This will force the pilot to use excessive forward pressure on the controls to maintain normal flight. Uncorrected, the aircraft will slow down and eventually stall.



Use the model airplane to demonstrate an aft centre of gravity.

---

### CONFIRMATION OF TEACHING POINT 3

---

#### QUESTIONS

- Q1. What is longitudinal stability?
- Q2. What does the horizontal stabilizer act like?
- Q3. What is the danger of an aft centre of gravity?

#### ANTICIPATED ANSWERS

- A1. Stability around the lateral axis.
- A2. A counterweight at the end of a lever.
- A3. Stall.

---

#### Teaching Point 4

Time: 10 min

#### Explain Lateral Stability

Method: Interactive Lecture

---

#### LATERAL STABILITY

Lateral stability is stability around the longitudinal axis and is called roll stability. To achieve lateral stability certain design features are built into the aircraft. Three of these design features are:

- dihedral,
- sweepback, and
- keel effect.

### The Effects of Dihedral and Anhedral

Dihedral is the angle that the wings make with the horizontal plane. As one looks at an aircraft from the front, the wings will slowly angle away from the ground so that the wing tip is higher than the wing root.

This assists the aircraft in maintaining lateral stability by changing the angle that the leading edge makes with the airflow.

When an aircraft with dihedral wings is forced in to a side-slipping motion, the down-going wing will meet the airflow at a right angle. This will increase the lift produced on that wing, forcing it back into place.

	Use the model airplane to demonstrate dihedral.
	Some aircraft have been designed with a negative dihedral, also known as anhedral. Anhedral acts opposite to dihedral, creating less stability. Usually found in aircraft with both sweepback and keel effect.

### The Effects of Sweepback

Similar to the dihedral, sweepback is a design feature where the wings sweep back instead of protruding straight out from the fuselage.

This assists the aircraft in maintaining lateral stability by changing the angle that the leading edge makes with the airflow.

When an aircraft with sweepback is forced into a slipping motion, the down going wing will meet the airflow at a right angle. This will increase the lift produced by that wing forcing it back into place.

	Use the model airplane to demonstrate sweepback.
---	--

### Keel Effect

While dihedral and sweepback are usually found on low-wing aircraft, high-wing aircraft have stability built-in. Since the bulk of the aircraft is below the plane of the wings, it acts as a keel. When a wing is forced up by a disturbance, the fuselage acts like a pendulum swinging the aircraft back into position.

	Use the model airplane to demonstrate keel effect.
---	--

---

## CONFIRMATION OF TEACHING POINT 4

---

### QUESTIONS

- Q1. What is lateral stability?
- Q2. What are three design features which provide lateral stability?
- Q3. How does keel effect work?



**ANTICIPATED ANSWERS**

- A1. Lateral stability is stability around the longitudinal axis.
- A2. Dihedral, sweepback, and keel effect.
- A3. When a wing is forced up by a disturbance, the fuselage acts like a pendulum swinging the aircraft back into position.

**Teaching Point 5****Explain Directional Stability and the Effects of the Fin**

Time: 5 min

Method: Interactive Lecture

**DIRECTIONAL STABILITY**

Directional stability is stability around the vertical or normal axis. The principle factor influencing directional stability is the vertical tail surface, or fin.

**The Effects of the Fin**

Aircraft, specifically airplanes, have a tendency of always flying head-on into the relative airflow. This tendency, called weather vaning, is a direct result of the vertical tail fin. If the aircraft yaws away from its course, the airflow strikes the fin from the side, forcing it back into position.

This will only work if the side area of the aircraft is greater aft of the centre of gravity than the area forward of the centre of gravity.



Use the model airplane to demonstrate the effects of the fin.

**CONFIRMATION OF TEACHING POINT 5****QUESTIONS**

- Q1. What is directional stability?
- Q2. What is the principle factor influencing directional stability?
- Q3. What is the effect of the fin?

**ANTICIPATED ANSWERS**

- A1. Directional stability is stability around the vertical or normal axis.
- A2. The principle factor influencing directional stability is the vertical tail surface, or fin.
- A3. If the airplane yaws away from its course, the airflow strikes the fin from the side, forcing it back into position.

---

**END OF LESSON CONFIRMATION**

---

**QUESTIONS**

- Q1. What is dynamic stability?
- Q2. What is the danger of an aft centre of gravity?
- Q3. What are three design features which provide lateral stability?

**ANTICIPATED ANSWERS**

- A1. The overall tendency of an aircraft to return to its original position.
- A2. Stall.
- A3. Dihedral, sweepback, and keel effect.

---

**CONCLUSION**

---

**HOMEWORK/READING/PRACTICE**

N/A.

**METHOD OF EVALUATION**

This EO is assessed IAW Chapter 3, Annex B, Aviation Subjects–Combined Assessment PC.

**CLOSING STATEMENT**

Aircraft, airplanes in particular, require a lot of stability in order to operate safely. All airplanes have stability designed into them. Commercial and private airplanes tend to have positive stability, while military fighters tend to have neutral or negative stability.

**INSTRUCTOR NOTES/REMARKS**

If EO C331.01 (Review Principles of Flight, Section 2) is chosen as a complementary period, it should be scheduled prior to this EO.

When developing activities for the mandatory familiarization flying/elemental training day, it is recommended that the cadet be given the opportunity to identify and describe the stability of the aircraft.

---

**REFERENCES**

---

- C3-116 (ISBN 0-9680390-5-7) MacDonald, A. F., & Pepler, I. L. (2000). *From the Ground Up: Millennium Edition*. Ottawa, ON: Aviation Publishers Co. Limited.
- C3-229 (ISBN 0-521-02128-6) Abzug, M. J., & Larrabee, E. E. (2002). *Airplane Stability and Control* (Second Edition). Cambridge, England: Cambridge University Press.



**ROYAL CANADIAN AIR CADETS**  
**PROFICIENCY LEVEL THREE**  
**INSTRUCTIONAL GUIDE**



**SECTION 2**

**EO C331.01 – REVIEW PRINCIPLES OF FLIGHT**

---

Total Time: 30 min

---

**PREPARATION**

---

**PRE-LESSON INSTRUCTIONS**

Resources needed for the delivery of this lesson are listed in the lesson specification located in A-CR-CCP-803/PG-001, Chapter 4. Specific uses for said resources are identified throughout the instructional guide within the TP for which they are required.

Review the lesson content and become familiar with the material prior to delivering the lesson.

Make copies of the handout located at Annex C for each cadet.

Make a slide of Annex C.

Bring a model airplane.

**PRE-LESSON ASSIGNMENT**

N/A.

**APPROACH**

An in-class activity was chosen for this lesson as an interactive way for the cadets to review the three axes of an aircraft and control surfaces.

---

**INTRODUCTION**

---

**REVIEW**

N/A.

**OBJECTIVES**

By the end of this lesson the cadet shall have reviewed principles of flight.

**IMPORTANCE**

It is important for cadets to review the principles of flight as a basis for learning new knowledge and skills. Comprehension of the basic principles of flight will enhance any familiarization flying activity.

---

**Teaching Point 1****Review the Three Axes of an Aircraft**

Time: 5 min

Method: In-Class Activity

---

---

**ACTIVITY**

---

**OBJECTIVE**

The objective of this activity is to review the three axes of an aircraft.

**RESOURCES**

- Handout located at Annex C,
- Slide of Annex C, and
- Overhead projector.

**ACTIVITY LAYOUT**

Arrange the classroom to allow for small group work.

**ACTIVITY INSTRUCTIONS**

1. Divide the cadets into groups of no more than four.
2. Distribute handout to each group.
3. Have the cadets label the diagram.
4. Have a cadet from each group move to another group and cross-check their answers. Have the cadets return to their group when done.
5. Project the slide onto a screen or wall.
6. Have a representative from three of the groups label one of the axes on the projected slide.

**SAFETY**

N/A.

---

**CONFIRMATION OF TEACHING POINT 1**

---

The cadets' participation in the in-class activity will serve as confirmation of this TP.

---

**Teaching Point 2****As a Member of a Group, Have the Cadet Describe a Control Surface and its Effects on Attitudes and Movements**

Time: 20 min

Method: In-Class Activity

---

---

**ACTIVITY**

---

**OBJECTIVE**

The objective of this activity is review control surfaces and their effects on attitudes and movements.

**RESOURCES**

- Model airplane,
- Flip chart paper, and
- Flip chart markers.

**ACTIVITY LAYOUT**

Arrange the classroom to allow for small group work.

**ACTIVITY INSTRUCTIONS**

1. Divide the cadets into equal groups.
2. Assign each group a control surface (rudder, aileron, or elevator).
3. Have the cadets illustrate, in the fullest detail possible, the control surface assigned to their group. Allow the cadets 10 minutes to complete their illustration.
4. Have the cadets post their group's illustration on the wall. Have the cadets conduct a gallery walk for five minutes.
5. With the remaining five minutes, lead the cadets in a discussion on each of the control surfaces. Use the model airplane for demonstration purposes.

**SAFETY**

N/A.

---

**CONFIRMATION OF TEACHING POINT 2**

---

The cadets' participation in the in-class activity will serve as confirmation of this TP.

---

**END OF LESSON CONFIRMATION**

---

The cadets' participation in the activity in TP 2 will serve as confirmation of this lesson.

---

**CONCLUSION**

---

**HOMEWORK/READING/PRACTICE**

N/A.

**METHOD OF EVALUATION**

N/A.

**CLOSING STATEMENT**

A review of principles of flight is important for understanding higher level material. Cadets who wish to pursue training in aviation must have a solid understanding of how aircraft fly.

**INSTRUCTOR NOTES/REMARKS**

If this complementary EO is chosen, it should be scheduled before any other EOs from this PO.

---

**REFERENCES**

---

- C3-116 (ISBN 0-9680390-5-7) MacDonald, A. F., & Pepler, I. L. (2000). *From the Ground Up: Millennium Edition*. Ottawa, ON: Aviation Publishers Co. Limited.



**ROYAL CANADIAN AIR CADETS**  
**PROFICIENCY LEVEL THREE**  
**INSTRUCTIONAL GUIDE**



**SECTION 3**

**EO C331.02 – READ PITOT STATIC INSTRUMENTS**

---

Total Time:	60 min
-------------	--------

---

**PREPARATION**

---

**PRE-LESSON INSTRUCTIONS**

Resources needed for the delivery of this lesson are listed in the lesson specification located in A-CR-CCP-803/PG-001, Chapter 4. Specific uses for said resources are identified throughout the instructional guide within the TP for which they are required.

Review the lesson content and become familiar with the material prior to delivering the lesson.

Photocopy the worksheets located at Annexes D, F, and H for each cadet.

Create OHPs of the answer keys located at Annexes E, G, and I.

Construct a working model of each of the pitot static instruments IAW Annex J.

**PRE-LESSON ASSIGNMENT**

N/A.

**APPROACH**

An interactive lecture was chosen for TPs 1 to 4 to introduce pitot static instruments.

An in-class activity was chosen for TP 5 as an interactive way to confirm the cadets' comprehension of pitot static instruments.

---

**INTRODUCTION**

---

**REVIEW**

N/A.

**OBJECTIVES**

By the end of this lesson the cadet shall be expected to read the airspeed indicator (ASI), altimeter, and vertical speed indicator (VSI).

**IMPORTANCE**

It is important for the cadets to be able to read pitot static instruments so that they are aware of what is happening in the aircraft while participating in familiarization flying or using a flight simulator.

---

**Teaching Point 1****Explain That the Basic Instruments of an Aircraft Rely on the Pitot Source and the Static Port as Sources of Information**

Time: 10 min

Method: Interactive Lecture

---

**BASIC INSTRUMENTS OF AN AIRCRAFT**

There are two main sources from which the pitot static instruments receive information. The first of these is the pitot source and the second is the static source.

**Pitot and Static Sources Provide Information for the ASI**

The pitot source on a light aircraft is usually a pitot tube which is attached to the nose or wing of the aircraft. The information from the pitot source goes directly to the ASI, which then translates the pressure into airspeed. Since the pitot source is facing forward, it acts as an intake for air. Therefore the faster the aircraft is moving, the greater the pressure at the pitot source, which in turn means the higher the reading on the ASI.

The ASI also receives information from the static source. This information will allow the ASI to compensate for changes in the air pressure when at different altitudes.

**Static Port Provides Information for the Altimeter**

The static port is a small vent on the side of the aircraft. This senses the surrounding pressure of the air and feeds it to the altimeter. The static port relies on changes in air pressure to work. For example, as the aircraft increases in altitude, the air pressure decreases. This causes the altimeter to indicate a higher altitude.

**Static Port Provides Information for the VSI**

The static port also provides information to the VSI. As the aircraft changes its altitude, the VSI will indicate the rate of change. This reading is based on the rate at which the surrounding air pressure is changing.



The ASI is the only pitot static instrument which receives pressure from both sources.

---

**CONFIRMATION OF TEACHING POINT 1**

---

**QUESTIONS**

- Q1. Which is the only instrument that uses the pitot source?
- Q2. Where on a light aircraft is the pitot source usually located?
- Q3. How does pressure affect the altimeter?

**ANTICIPATED ANSWERS**

- A1. ASI.
- A2. The pitot source is usually attached to the nose or wing.
- A3. As pressure decreases, the indicated altitude on the altimeter will increase.



---

**Teaching Point 2****Explain How to Read an ASI**

Time: 10 min

Method: Interactive Lecture

---

**READ THE AIRSPEED INDICATOR (ASI)**

Reading the ASI is straightforward, and is nearly the same as reading a speedometer in a car. There is one needle and it points to the speed at which the aircraft is travelling. The biggest difference between the speedometer and the ASI is that the ASI has a colour code lining the speed scale.

Each of these arcs represent a speed range for certain flying conditions. The three colours common to all ASIs are:

- green,
- yellow, and
- red.



*North American Powered Parachute Federation, "Flight Instruments". Retrieved October 30, 2007, from [http://www.nappf.com/nappf\\_flight\\_instruments.htm](http://www.nappf.com/nappf_flight_instruments.htm)*

Figure 12-3-1 Airspeed Indicator

**Normal Operating Range**

The green arc indicates safe and normal flying speeds. During normal flying the pilot will modify engine power and pitch attitude so that the airspeed flown is somewhere within the green arc. This does not apply for the early part of takeoff or the last part of landing, and may not apply during aerobatic manoeuvres.

**Cautionary Range**

The yellow arc indicates the cautionary speed range. The aircraft can fly safely at speeds in the yellow arc range, but only if manoeuvres are kept small and gentle. Aggressive manoeuvres at speeds in the yellow arc can cause structural damage to the aircraft.

**Never Exceed Speed**

The red line indicates the maximum speed that the aircraft should be flown at under any circumstances. If the airspeed exceeds the red line speed, then the aircraft has to be grounded and undergo a structural inspection. Exceeding the red line may cause structural damage.

## Units of Measurement

When reading the ASI, it is very important to know what units of measurement are used. In most ASIs, the unit of measurement is knots indicated airspeed (KIAS). In slower aircraft ASIs may use miles per hour (mph) as the unit of measurement. The difference between the two units is that one nautical mile (used for KIAS) is 6 080 feet, whereas one statute mile is 5 280 feet.

---

### ACTIVITY

Time: 5 min

---

#### OBJECTIVE

The objective of this activity is for the cadet to practice reading an ASI.

#### RESOURCES

- ASI worksheet located at Annex D, and
- OHP of the answer key located at Annex E.

#### ACTIVITY LAYOUT

N/A.

#### ACTIVITY INSTRUCTIONS

1. Divide the cadets into pairs.
2. Distribute the ASI worksheet to each cadet.
3. Allow the cadets two to three minutes to complete the worksheet.
4. Allow the cadets two minutes to share and review answers with their partner.
5. Show the OHP of the answer key.

#### SAFETY

N/A.

---

### CONFIRMATION OF TEACHING POINT 2

---

The cadets' participation in the activity will serve as the confirmation of this TP.

---

#### Teaching Point 3

#### Explain How to Read an Altimeter

Time: 10 min

Method: Interactive Lecture

---

#### READ AN ALTIMETER

The altimeter is the instrument which tells the pilot how high above sea level (ASL) the aircraft is. In North America the altimeter measures in feet ASL.

## Units of Measurement

Every altimeter has at least three hands: one long, one short and stubby, and one long and thin with a triangle on the end.



*North American Powered Parachute Federation, "Flight Instruments". Retrieved October 30, 2007, from [http://www.nappf.com/nappf\\_flight\\_instruments.htm](http://www.nappf.com/nappf_flight_instruments.htm)*

Figure 12-3-2 The Altimeter

The long hand measures altitude in hundreds of feet ASL. This is the fastest moving hand of the three and a change in altitude will make it move.

The short hand measures altitude in thousands of feet ASL. This hand moves slowly as the altitude changes. Every time the long hand goes through a 360-degree rotation, the short hand will move to the next number on the dial.

The third hand is the thinnest and the slowest moving. It measures altitude in tens of thousands of feet ASL. As the short hand goes through a 360-degree rotation the short hand will move to the next number indicating ten thousand, twenty thousand, thirty thousand feet ASL and so on.

### Pressure Sub-Scale

On the right hand side of the altimeter, there is a sub-scale. This sub-scale is used to adjust the altimeter to account for differences in the pressure of the surrounding air. The altimeter is sensitive to air pressure, and readings will change as pressure changes. Pilots have to be diligent and ensure that the sub-scale is set properly.

### Field Elevation Versus Pressure Altitude

The sub-scale relies on pressure altitude to calibrate the altimeter. Pressure altitude is the perceived altitude based on the current air pressure. If this information is not available, pilots can set their altimeter to the elevation of the airfield, called field elevation. This will set the altimeter sub-scale to the proper reading.

### Height Above Sea Level (ASL)/Above Ground Level (AGL)

The altimeter is designed to be used relative to sea level and is used on long flights where the ground changes in elevation. When arriving and departing an airport, all procedures are followed relative to the height above the ground. This is known as height AGL.



Reading an altimeter is very similar to reading an analog clock. Every time the second hand passes 12, the minute hand advances to the next minute. Every time the minute hand passes 12, the hour hand advances to the next hour. The altimeter works the same way.

---

### ACTIVITY

Time: 5 min

---

#### OBJECTIVE

The objective of this activity is to allow the cadet to practice reading an altimeter.

#### RESOURCES

- Altimeter worksheet located at Annex F, and
- OHP of the answer key located at Annex G.

#### ACTIVITY LAYOUT

N/A.

#### ACTIVITY INSTRUCTIONS

1. Distribute the altimeter worksheet to each cadet.
2. Using the first two questions as examples, show the cadets how to read the altimeter.
3. Have the cadets complete the worksheet with a partner.
4. Show the OHP of the answer key.

#### SAFETY

N/A.

---

### CONFIRMATION OF TEACHING POINT 3

---

The cadets' participation in the activity will serve as the confirmation of this TP.

---

#### Teaching Point 4

#### Explain How to Read a VSI

Time: 10 min

Method: Interactive Lecture

---

### READ A VERTICAL SPEED INDICATOR (VSI)

The VSI is an instrument, which measures the rate at which the aircraft is changing altitude.

#### Units of Measurement

The VSI is different than the altimeter in that the altimeter measures the exact height ASL, whereas the VSI measures how fast the aircraft is gaining or losing altitude in feet per minute.

### Positive/Negative Rates of Climb

The VSI is divided in half, top and bottom. Both halves are measured in increments of 100 feet, represented by the numbers 1–10 or 1–20. When the needle on the VSI is pointed to the number 1, it means 100 feet per minute. The top half is a positive rate of change in altitude or rate of climb, while the bottom half is a negative rate of change in altitude or rate of descent.



*North American Powered Parachute Federation, "Flight Instruments". Retrieved October 30, 2007, from [http://www.nappf.com/nappf\\_flight\\_instruments.htm](http://www.nappf.com/nappf_flight_instruments.htm)*

Figure 12-3-3 The Vertical Speed Indicator

### ACTIVITY

Time: 5 min

#### OBJECTIVE

The objective of this activity is to allow the cadet to practice reading the VSI.

#### RESOURCES

- VSI worksheet located at Annex H, and
- OHP of the answer key located at Annex I.

#### ACTIVITY LAYOUT

N/A.

#### ACTIVITY INSTRUCTIONS

1. Distribute VSI worksheet to each cadet.
2. Have the cadets to complete the worksheet.
3. Show the OHP of the answer key.

#### SAFETY

N/A.

---

**CONFIRMATION OF TEACHING POINT 4**

---

The cadets' participation in the activity will serve as the confirmation of this TP.

---

**Teaching Point 5**

**Have the Cadet Read Pitot Static Instruments**

Time: 10 min

Method: In-Class Activity

---

**ACTIVITY**

---

**OBJECTIVE**

The objective of this activity is for the cadet to practice reading pitot static instruments.

**RESOURCES**

- One working model of each of the pitot static instruments, including:
  - ASI,
  - Altimeter, and
  - VSI; and
- Questions located at Annex K.

**ACTIVITY LAYOUT**

N/A.

**ACTIVITY INSTRUCTIONS**

1. Divide the cadets into two teams.
2. Set one model at a time (in no particular order) and allow each team five seconds to read the instrument.
3. Alternate which team answers. The teams get one point for every correct answer that they give.
4. If a team cannot correctly answer the question within five seconds then the other team can steal the point.
5. The team which answers the most questions correctly wins.

**SAFETY**

N/A.

---

**CONFIRMATION OF TEACHING POINT 5**

---

The cadets' participation in the activity will serve as the confirmation of this TP.

---

**END OF LESSON CONFIRMATION**

---

The cadets' participation in each of the activities will serve as the confirmation of this lesson.

---

**CONCLUSION**

---

**HOMEWORK/READING/PRACTICE**

N/A.

**METHOD OF EVALUATION**

N/A.

**CLOSING STATEMENT**

Knowing how to read the pitot static instruments is essential in order to fly an aircraft. Even if a pilot is not flying under IFR conditions, these three instruments are required in order to safely operate the aircraft. They also allow the pilot to coordinate with other pilots and ATS to ensure traffic avoidance or to fly circuits at an aerodrome.

**INSTRUCTOR NOTES/REMARKS**

N/A.

---

**REFERENCES**

---

- C3-116 (ISBN 0-9680390-5-7) MacDonald, A. F., & Pepler, I. L. (2000). *From the Ground Up: Millennium Edition*. Ottawa, ON: Aviation Publishers Co. Limited.
- C3-139 (ISBN 0-7715511-5-0) Transport Canada. (1999). *Flight Training Manual: 4<sup>th</sup> Edition Revised*. Ottawa, ON: Transport Canada.

THIS PAGE INTENTIONALLY LEFT BLANK





**ROYAL CANADIAN AIR CADETS**  
**PROFICIENCY LEVEL THREE**  
**INSTRUCTIONAL GUIDE**



**SECTION 4**

**EO C331.03 – IDENTIFY ASPECTS OF HELICOPTER AERODYNAMICS**

---

Total Time:	30 min
-------------	--------

---

**PREPARATION**

---

**PRE-LESSON INSTRUCTIONS**

Resources needed for the delivery of this lesson are listed in the lesson specification located in A-CR-CCP-803/PG-001, Chapter 4. Specific uses for said resources are identified throughout the instructional guide within the TP for which they are required.

Review the lesson content and become familiar with the material prior to delivering the lesson.

Create slides of Annexes L and M.

Bring a model helicopter to class. If possible use a radio-controlled helicopter to illustrate helicopter aerodynamics.

**PRE-LESSON ASSIGNMENT**

N/A.

**APPROACH**

An interactive lecture was chosen for this lesson to introduce the cadets to aspects of helicopter aerodynamics.

---

**INTRODUCTION**

---

**REVIEW**

N/A.

**OBJECTIVES**

By the end of this lesson the cadet shall be expected to identify aspects of helicopter aerodynamics.

**IMPORTANCE**

It is important for cadets to identify aspects of helicopter aerodynamics so that they can appreciate the differences between airplanes and helicopters.

**Teaching Point 1****Describe the Main Rotor of a Helicopter**

Time: 15 min

Method: Interactive Lecture

**THE MAIN ROTOR OF A HELICOPTER**

Helicopters, like airplanes, have airfoils. Unlike airplanes, which have fixed airfoils (wings), the airfoils of a helicopter are not in a fixed position. The airfoils on a helicopter are called rotor blades, which are attached to a rotating point on the top of the helicopter's airframe. The whole assembly is referred to as the main rotor or rotor system.

The terms "fixed wing" (airplane) and "rotary wing" (helicopter) are derived from the physical differences between airplane and helicopter airfoils.



Use the model of the helicopter to illustrate each of the following points. If possible, a radio-controlled helicopter model should be used as it will dynamically illustrate the concepts of rotor thrust and rotor drag.

**Rotor Systems**

The rotor systems of a helicopter incorporate many parts. Three of the basic parts are:

- the rotor blades,
- the rotor head, and
- the drive shaft.

The rotor blades are attached to the rotor head. The rotor head sits on top of the drive shaft. As the drive shaft spins, it moves the blades through the air.

As the blades spin, they act like the wings of an airplane. The shape of the rotor blade is symmetrical, meaning that the top of the blade is shaped the same as the bottom of the blade. As each blade passes through the air, the airflow over the blade creates lift using the same principles of a wing.

In order for a helicopter to move in a horizontal direction, the rotor system must be angled in the direction of travel. This changes the angle of the plane in which the blades rotate, and the rotor blades act the same as propellers.

Flying a helicopter is complicated. Once the angle of the plane of rotation has been changed, the amount of lift being produced will no longer be enough to maintain the helicopter's altitude. The pilot must apply more power in order to counteract this. The total lift force required to maintain the helicopter's altitude and forward motion is referred to as total rotor thrust.

**Rotor Drag**

Rotor drag is the opposite of rotor thrust. It is commonly known as torque, and acts opposite to the direction that each blade travels. Rotor drag attempts to slow down the rotation of the blades and an increase in engine power is required to maintain the speed of the blades. If the force of rotor drag is stronger than the rotor thrust, then the torque causes the body of the helicopter to rotate instead of the blades.

Rotor drag should not be confused with aerodynamic drag.



Aerodynamic drag is a force that acts on the body of the aircraft as it moves through the air. It acts opposite to thrust (see the four forces acting on an aircraft).

### Factors Influencing Rotor Thrust

There are four factors that influence rotor thrust, including:

- **Air Density.** As the rotor blades pass through the air, the reaction between the air molecules and the surface of the blade produces lift. More air molecules will create a stronger reaction. One may state that more lift is produced in higher density air vice lower density air because dense air has more molecules. Air density can decrease with increases in temperature or decreases in pressure.
- **Rotor Revolutions per Minute (rpm).** An increase in rotor rpm increases the total rotor thrust, while a decrease in rotor rpm decreases the total rotor thrust.
- **Blade (Pitch) Angle.** An increase in the blade angle increases the total rotor thrust, while a decrease in the blade angle decreases the total rotor thrust. This is similar to the effects of pitch on an airplane's wings.
- **Disc Area.** Disc area is the total area in which the rotor blades rotate and is determined by the length of the rotor blades. The larger the disc area is, the higher the total rotor thrust will be. This follows the same principle with airplanes, where the larger the wing area, the more lift is produced.

---

### CONFIRMATION OF TEACHING POINT 1

---

#### QUESTIONS

- Q1. What are the three basic parts of a rotor system?
- Q2. Which force acts opposite to rotor thrust?
- Q3. How does disc area influence rotor thrust?

#### ANTICIPATED ANSWERS

- A1. The rotor blades, rotor head, and drive shaft.
- A2. Rotor drag.
- A3. The larger the disc area is, the higher the total rotor thrust will be.

---

#### Teaching Point 2

#### Describe the Anti-Torque Rotor of a Helicopter

Time: 5 min

Method: Interactive Lecture

---

#### THE ANTI-TORQUE ROTOR



Show slide of Annex L.

## Location on the Airframe

The anti-torque rotor is a smaller version of the main rotor. It is mounted vertically at the end of the tail. Most helicopters have an anti-torque rotor that sits in the right side of the tail, although some designs have the anti-torque rotor mounted on the left side or built into the tail assembly.



*Airforce Imagery, 2008, CH-149 Cyclone. Copyright 2006 by Sikorsky Aircraft Corporation.  
Retrieved April 9, 2008, from [http://www.airforceimagery.forces.gc.ca/netpub/server.np?find&catalog=casimages&template=detail2\\_e.np&field=itemid&op=matches&value=3018&site=casimages](http://www.airforceimagery.forces.gc.ca/netpub/server.np?find&catalog=casimages&template=detail2_e.np&field=itemid&op=matches&value=3018&site=casimages)*

Figure 12-4-1 Location of Anti-Torque Rotor

## Function

The function of the anti-torque rotor is to counteract the torque produced by the main rotor. Without the anti-torque rotor, the rotation of the main rotor would transfer to the airframe and rotate the airframe instead of the rotor blades. By installing the anti-torque rotor, the airframe stays relatively still while the rotor blades rotate above the airframe. The anti-torque rotor serves to control movement around the vertical axis of the helicopter.

## Power Source

The anti-torque rotor receives power from the main engine through a drive shaft which runs the length of the tail assembly.

---

## CONFIRMATION OF TEACHING POINT 2

---

### QUESTIONS

- Q1. Where is the anti-torque rotor normally located?
- Q2. What are the functions of the anti-torque rotor?
- Q3. How does the anti-torque rotor receive power?

### ANTICIPATED ANSWERS

- A1. It is mounted vertically at the end of the tail.
- A2. The functions of the anti-torque rotor are to counteract the torque produced by the main rotor and to control movement around the vertical axis.

- A3. The anti-torque rotor receives power from the main engine through a drive shaft, which runs the length of the tail assembly.

---

**Teaching Point 3****Explain the Control Inputs of a Helicopter**

Time: 5 min

Method: Interactive Lecture

---

**CONTROL INPUTS OF A HELICOPTER**

There are three primary control inputs of a helicopter. They differ from the control inputs of an airplane in some ways, but are similar in others. The three primary control inputs are:

- collective,
- cyclic, and
- pedals.



Show slide of Annex M.

**Collective**

The collective is an arm lever located on the left side of the pilot's seat (in most helicopters the pilot sits on the right side of the cockpit). The collective controls the angle of attack of the rotor blades which will affect the amount of lift produced. Pulling up on the collective will increase the angle of attack, producing more lift. Pushing down on the collective will decrease the angle of attack, producing less lift.

At the end of the collective is a throttle. The throttle on a helicopter is a twist-style grip. The throttle controls the rpm of the blades. An increase in rpm will increase the amount of lift produced and the speed at which the helicopter travels.

It is important to remember that the rotors act in the same way as both the wings and the propeller of an airplane. They produce the lift and the thrust. The same happens for movements forward, backward and to the right.

**Cyclic**

In a helicopter, the control column is known as the cyclic. The cyclic controls the angle of the plane in which the rotor blades move. Moving the cyclic left will angle the rotation of the blades left. Maintaining that angle long enough will move the helicopter to the left.

**Pedals**

The pedals in a helicopter cockpit are similar to rudder pedals. They control the anti-torque rotor, providing directional stability. They also control which direction the nose of the helicopter is pointed. One of the unique capabilities of a helicopter is that the nose can be pointed in a different direction than the direction of travel. This provides the helicopter increased manoeuvrability.

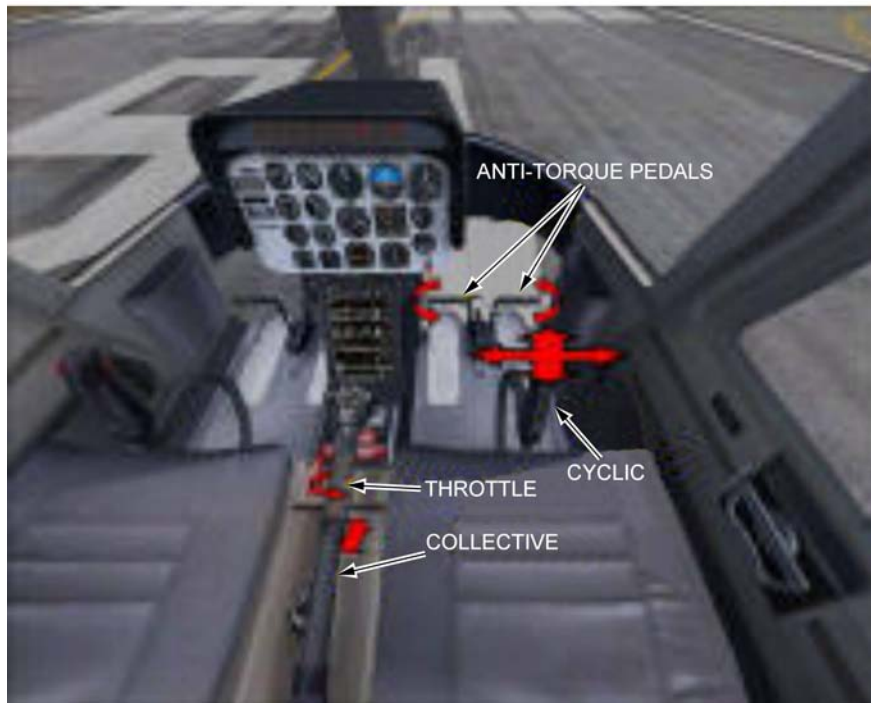

*AVSIM Online, by S. Cartwright, 2004, Helicopter Tutorial. Copyright 2004 by AVSIM Online. Retrieved April 8, 2008, from <http://www.avsim.com/pages/0604/heli/helitutorial.htm>*

Figure 12-4-2 Helicopter Control Inputs

---

### CONFIRMATION OF TEACHING POINT 3

---

#### QUESTIONS

- Q1. What does the collective control?
- Q2. What does the cyclic control?
- Q3. What do the pedals control?

#### ANTICIPATED ANSWERS

- A1. The angle of attack of the rotor blades.
- A2. The angle of the plane in which the rotor blades move.
- A3. They control the anti-torque rotor, providing directional stability. They also control which direction the nose of the helicopter is pointed.

---

### END OF LESSON CONFIRMATION

---

#### QUESTIONS

- Q1. How do the main rotor systems produce lift?
- Q2. What is the function of the anti-torque rotor?
- Q3. What is one of the unique capabilities of helicopters?

**ANTICIPATED ANSWERS**

- A1. As each blade passes through the air, the airflow over the blade creates lift using the same principles as a wing.
- A2. The function of the anti-torque rotor is to counteract the torque produced by the main rotor.
- A3. One of the unique capabilities of a helicopter is that the nose can be pointed in a different direction than the direction of travel.

---

**CONCLUSION**

---

**HOMEWORK/READING/PRACTICE**

N/A.

**METHOD OF EVALUATION**

N/A.

**CLOSING STATEMENT**

Helicopters are flown using very different applications of Newtonian physics. Certain parts of the helicopter are similar to airplanes but have different functions. These differences make the helicopter a more manoeuvrable aircraft and more challenging to fly.

**INSTRUCTOR NOTES/REMARKS**

It is recommended that this EO be scheduled with EO C331.05 (Tour a Local Aviation Facility, A-CR-CCP-803/PG-001, Chapter 4, Section 13) if helicopters are present at the facility.

If the squadron has the opportunity to participate in familiarization flights in a helicopter, this EO should be conducted at that time.

---

**REFERENCES**

---

- C3-249 (ISBN 978-1-56027-649-4) Wagtendok, W. J. (2006). *Principles of Helicopter Flight: Second US Edition*. Newcastle, WA: Aviation Supplies & Academics, Inc.

THIS PAGE INTENTIONALLY LEFT BLANK





**ROYAL CANADIAN AIR CADETS**  
**PROFICIENCY LEVEL THREE**  
**INSTRUCTIONAL GUIDE**



**SECTION 5**

**EO C331.04 – DEMONSTRATE ATTITUDES AND MOVEMENTS IN A FLIGHT SIMULATOR**

Total Time: 90 min

**PREPARATION**

**PRE-LESSON INSTRUCTIONS**

Resources needed for the delivery of this lesson are listed in the lesson specification located in A-CR-CCP-803/PG-001, Chapter 4. Specific uses for said resources are identified throughout the instructional guide within the TP for which they are required.

Review the lesson content and become familiar with the material prior to delivering the lesson.

Create a scenario for the computer simulator IAW the manual provided with the software. The guidelines for this scenario should be using a local airport, no weather, and a starting altitude of 5 500 feet ASL.

**PRE-LESSON ASSIGNMENT**

N/A.

**APPROACH**

An interactive lecture was chosen for TPs 1 and 2 to give direction on procedures and present basic or background information about flight simulation.

A simulation was chosen for TP 3 as it is an interactive way to allow the cadet to experience attitudes and movements in a safe, controlled environment. This activity contributes to the development of principles of flight skills and knowledge in a fun and challenging setting.

**INTRODUCTION**

**REVIEW**

N/A.

**OBJECTIVES**

By the end of this lesson the cadet shall be expected to demonstrate attitudes and movements and read pitot static instruments in a flight simulator.

**IMPORTANCE**

It is important for cadets to apply this knowledge in a flight simulator to enhance the learning value of attitudes and movements. This will also serve as a solid foundation for any cadet who participates in flight training in the future.

**Teaching Point 1****Explain Safety Considerations Related to the Location or Design of the Flight Simulator**

Time: 5 min

Method: Interactive Lecture



Arrange the cadets so they can hear the safety briefing prior to using the flight simulator.



This briefing is being conducted to pass on safety considerations for use of the flight simulator. The actual content of the briefing will vary by region and squadron based on the squadron's assets, the location of the assets, and other environmental factors. The following should be covered:

- DND regulations concerning the appropriate use of computers, including:
  - CATO 11-07 (Internet Acceptable Use – Cadet Program),
  - DAOD 6001 (Internet),
  - Regional Orders, and
  - Squadron Standing Orders;
- location of the nearest fire exit in case of fire;
- awareness of any moving parts of the simulator; and
- proper entry and exit techniques to avoid damage to assets.

**CONFIRMATION OF TEACHING POINT 1**

Confirmation of this TP will depend on the actual content covered.

**Teaching Point 2****Explain How to Manipulate the Necessary Control Inputs and the Location of Necessary Instruments**

Time: 15 min

Method: Interactive Lecture

**CONTROL COLUMN OR YOKE**

Using a control column or yoke in a flight simulator is preferable. Accordingly, the following will need to be adjusted if a control column is used instead.

The control yoke is located directly in front of the pilot in the centre of the pilot's side of the instrument panel. The control yoke is very much like the steering wheel of a car, both in look and function. The yoke is designed to move on two planes of motion.

The first plane of motion is left and right. The standard yoke will usually move to approximately 45 degrees left or right of centre when moved like a steering wheel. This motion is what controls the ailerons of the simulated airplane. To roll left, turn the wheel left. To roll right, turn the wheel right. Remember, this must be used as well as the rudder in order to properly turn the aircraft.

The control yoke also moves back and forth. The steering column of the yoke moves in and out of the main assembly. This controls the elevator of the simulated aircraft. To pitch up, pull back (towards the pilot). To pitch down, push forward (away from the pilot).



Pitch will change your altitude, but more importantly your airspeed.

### **RUDDER PEDALS**

On the floor of the simulator there are two pedals. If you push forward on the left pedal, the right one moves back and vice versa. These pedals control the rudder of the simulated aircraft. To yaw left, push on the left pedal. To yaw right, push on the right pedal.



Rudder pedals move in different directions so pressure must be taken off the opposite pedal in order for the movement to take place.

### **LOCATION OF INSTRUMENTS**

The instruments of the simulated aircraft will be displayed in front of the pilot, laid out on what is called an instrument panel. The three instruments that are of significance are the pitot static instruments: the airspeed indicator (ASI), vertical speed indicator (VSI), and altimeter. They are usually located just above the control yoke in a cluster of six instruments.

**ASI.** The ASI is located on the top row of the instrument panel on the far left.

**VSI.** The VSI is located on the bottom row of the instrument panel on the far right.

**Altimeter.** The altimeter is located on the top row of the instrument panel on the far right, just above the VSI.



*"Design a Virtual Cockpit Instrument Panel", Ngee Ann Polytechnic, 2007. Retrieved October 31, 2007, from <http://www.learnerstogether.net/avionics-project-design-problem-based-learning/56>*

Figure 12-5-1 Cessna Flight Instrument Panel



There is no need to go in to any detail about the other three instruments located in the diagram.

---

## CONFIRMATION OF TEACHING POINT 2

---

### QUESTIONS

- Q1. Where is the control yoke located?
- Q2. Where are the pitot static instruments located?
- Q3. How is pitch controlled?

### ANTICIPATED ANSWERS

- A1. In front of the pilot centred on the instrument panel.
- A2. Clustered together, just above the control yoke.
- A3. By moving the yoke towards or away from the pilot.

**Teaching Point 3****Supervise the Cadets as They Practice Attitudes and Movements Using the Flight Simulator**

Time: 60 min

Method: Simulation

**ACTIVITY****OBJECTIVE**

The objective of this activity is to allow the cadet to practice attitudes and movements and witness their effect on the pitot static instruments.

**RESOURCES**

- Computer flight simulator (Microsoft flight simulator, computer, control yoke, and rudder pedals), and
- Scenario using local airport, no weather, and a starting altitude of 5 500 feet ASL.

**ACTIVITY LAYOUT**

This will depend on the location of the simulator.

**ACTIVITY INSTRUCTIONS**

1. Start the simulator with the scenario created prior to the lesson.
2. Allow the cadets to take turns in the simulator, practicing attitudes and movements.
3. Each cadet should be given an equal amount of time. This means that the 60 minutes should be divided as evenly as possible by the number of cadets in the class.
4. If a cadet is quickly grasping the concepts, move on to the next cadet. This will allow some flexibility in the event a cadet does not grasp the concepts quickly.

**SAFETY**

N/A.

**CONFIRMATION OF TEACHING POINT 3**

The cadets' participation in this activity will serve as confirmation of this TP.

**END OF LESSON CONFIRMATION**

The cadets' participation in the flight simulator, practicing attitudes and movements, will serve as confirmation of this lesson.

**CONCLUSION****HOMEWORK/READING/PRACTICE**

N/A.

## **METHOD OF EVALUATION**

N/A.

## **CLOSING STATEMENT**

It has been stated by many flight instructors that a significant difference can be seen in the skill quality of students who used a flight simulator compared to those who did not. The military is a large user of computer-based flight simulators, as are Air Canada and WestJet. Cadets are encouraged to train on flight simulators as it will enhance their preparation for future flight training.

## **INSTRUCTOR NOTES/REMARKS**

Concurrent activities may be required based on the number of simulators available.

All staff should be familiar with the operation of the flight simulator prior to the EO. This will better prepare them to troubleshoot and instruct.

---

## **REFERENCES**

---

- C3-139 (ISBN 0-7715511-5-0) Transport Canada. (1999). *Flight Training Manual: 4<sup>th</sup> Edition Revised*. Ottawa, ON: Transport Canada.
- C3-156 *Computerized Aircraft Simulation Center*. (2007). Retrieved October 2, 2007, from [http://www.regions.cadets.forces.gc.ca/pac/aircad/flight/casc\\_lessons\\_e.asp](http://www.regions.cadets.forces.gc.ca/pac/aircad/flight/casc_lessons_e.asp).

## THE FOUR STATIONS

### **Station 1: Tennis Ball – Dynamic and Static Stability**

This station should be set up in an area of the classroom where there will be a six-foot (2-metre) length of unobstructed floor space. Place a piece of tape on the floor to mark the starting position. Place a tennis ball on the piece of tape.

1. Have the cadet pick up the ball to shoulder height (thus displacing it from its original position) and then drop it back on to the floor.
2. Have the cadet observe the tennis ball as it bounces.
3. The initial bounce is the static stability, while the remaining bounces reflect dynamic stability.

### **Station 2: Marble With Bowl – Positive Stability**

In the centre of the table place the bowl, right-side up. Place a marble in the centre of the bowl.

1. Have the cadet push the marble with their finger to just below the lip of the bowl.
2. Allow the marble to fall back to the bottom of the bowl.
3. Observe the results.
4. The end result is that the marble will return to its original place; positive stability.

### **Station 3: Marble on Flat Level Surface – Neutral Stability**

Place a marble on one end of a table.

1. Have the cadet gently push the marble towards the other end of the surface.
2. Observe the marble as it rolls and then stops.
3. The marble is now in a new position, neither moving further away nor moving back to its starting place.

### **Station 4: Marble With Bowl – Negative Stability**

This station should be set up on a table. In the centre of the table, place a bowl, upside down. Place a marble on top of the bowl.

1. Have the cadet gently push the marble towards the edge of the bowl's base.
2. Watch as the marble continues to move away from its starting place. This is negative stability.
3. Have the cadets chase after the marble and replace it. Replacing the marble is not part of the demonstration of negative stability.

THIS PAGE INTENTIONALLY LEFT BLANK



### CONTROL SURFACES

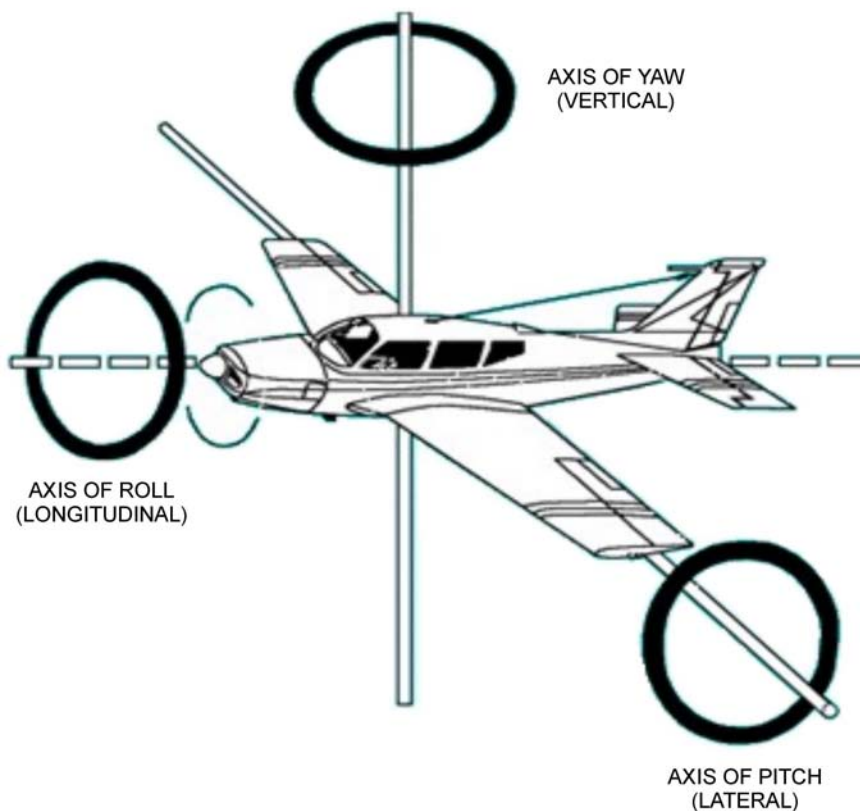

*"Start Flying", Controlling the Aircraft, (2007). Retrieved October 24, 2007, from [http://www.startflying.com/new%20site/controlling\\_aircraft.htm](http://www.startflying.com/new%20site/controlling_aircraft.htm)*

Figure 12B-1 Axes of Rotation

THIS PAGE INTENTIONALLY LEFT BLANK

### AXES OF ROTATION

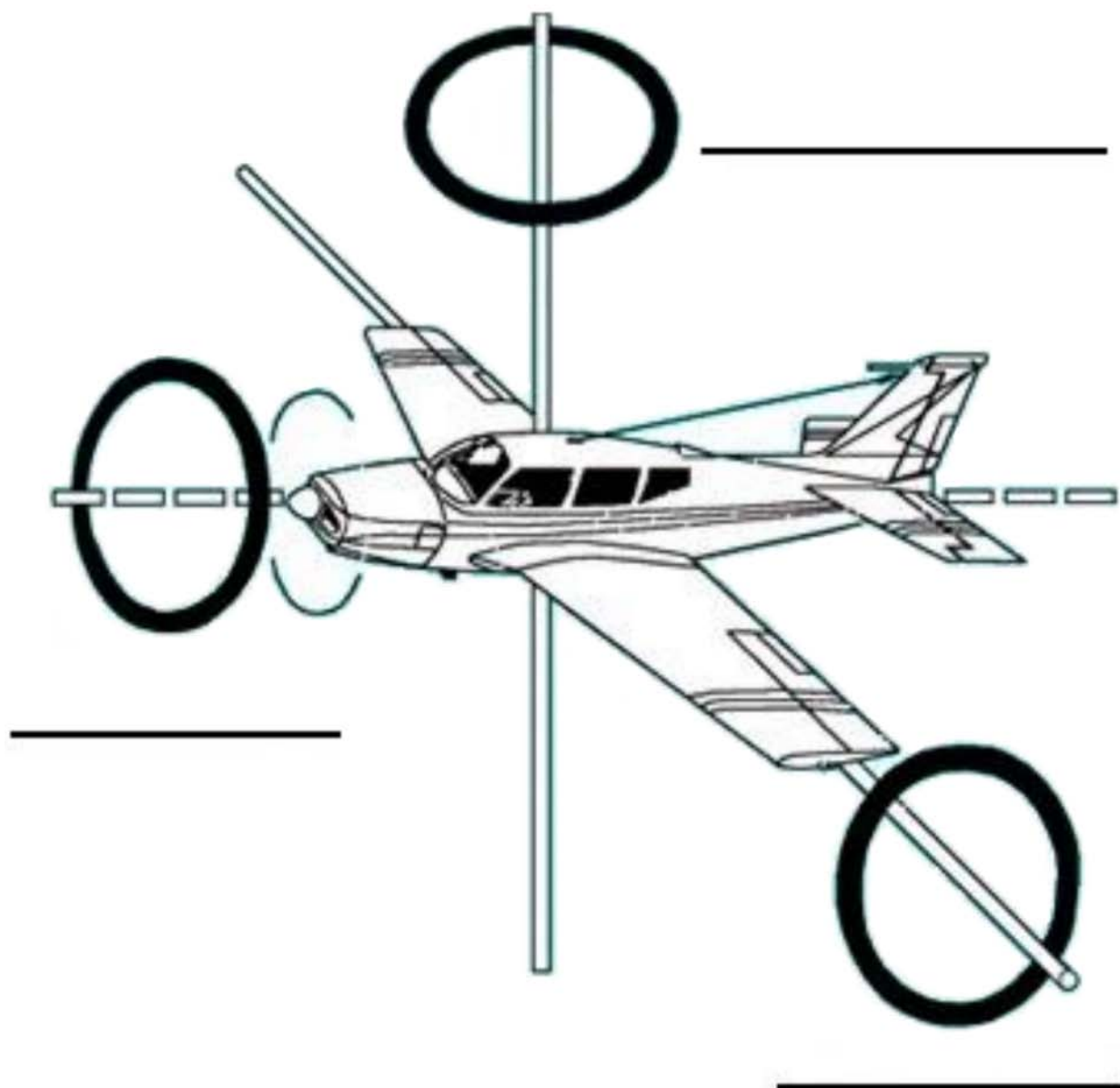

*"Controlling the Aircraft", Start Flying, (2007). Retrieved October 24, 2007, from [http://www.startflying.com/new%20site/controlling\\_aircraft.htm](http://www.startflying.com/new%20site/controlling_aircraft.htm)*

Figure 12C-1 Axes of Rotation

THIS PAGE INTENTIONALLY LEFT BLANK

### ASI WORKSHEET



\_\_\_\_\_ KNOTS



\_\_\_\_\_ KNOTS



\_\_\_\_\_ KNOTS



\_\_\_\_\_ KNOTS



\_\_\_\_\_ KNOTS



\_\_\_\_\_ KNOTS

*Director Cadets 3, 2008, Ottawa, ON: Department of National Defence*

Figure 12D-1 ASI Worksheet

THIS PAGE INTENTIONALLY LEFT BLANK

ASI ANSWER KEY



30 KNOTS



50 KNOTS



170 KNOTS



98 KNOTS



120 KNOTS



65 KNOTS

*Director Cadets 3, 2008, Ottawa, ON: Department of National Defence*

Figure 12E-1 ASI Answer Key

THIS PAGE INTENTIONALLY LEFT BLANK



### ALTIMETER WORKSHEET



\_\_\_\_\_ FEET ASL



\_\_\_\_\_ FEET ASL



\_\_\_\_\_ FEET ASL



\_\_\_\_\_ FEET ASL



\_\_\_\_\_ FEET ASL



\_\_\_\_\_ FEET ASL

*Director Cadets 3, 2008, Ottawa, ON: Department of National Defence*

Figure 12F-1 Altimeter Worksheet

THIS PAGE INTENTIONALLY LEFT BLANK

**ALTIMETER ANSWER KEY**



500 FEET ASL



1000 FEET ASL



1300 FEET ASL



1750 FEET ASL



2100 FEET ASL



2750 FEET ASL

*Director Cadets 3, 2007, Ottawa, ON: Department of National Defence*

Figure 12G-1 Altimeter Answer Key

THIS PAGE INTENTIONALLY LEFT BLANK

VSI WORKSHEET



\_\_\_\_ FEET PER MINUTE



\_\_\_\_ FEET PER MINUTE



\_\_\_\_ FEET PER MINUTE



\_\_\_\_ FEET PER MINUTE



\_\_\_\_ FEET PER MINUTE



\_\_\_\_ FEET PER MINUTE

*Director Cadets 3, 2007, Ottawa, ON: Department of National Defence*

Figure 12H-1 VSI Worksheet

THIS PAGE INTENTIONALLY LEFT BLANK

VSI ANSWER KEY



0 FEET PER MINUTE



+200 FEET PER MINUTE



+700 FEET PER MINUTE



-50 FEET PER MINUTE



-400 FEET PER MINUTE



-800 FEET PER MINUTE

*Director Cadets 3, 2007, Ottawa, ON: Department of National Defence*

Figure 12I-1 VSI Answer Sheet

THIS PAGE INTENTIONALLY LEFT BLANK



## INSTRUCTIONS FOR CREATION OF PITOT STATIC INSTRUCTIONAL AIDS

### RESOURCES

- One sheet of Bristol board per training aid,
- One brass Acco fastener per training aid,
- Pencil,
- Compass from a geometry set,
- Ruler or straight edge,
- Coloured markers, and
- Poster board for making dial hands.

### INSTRUCTIONS – ASI

1. Draw a representation of an ASI centred on the Bristol board. This will include all of the numbers and coloured arcs/lines. Use figures located at Annex D as guides for layout.
2. Colour in the arcs and lines with the appropriate colours for the green arc, yellow arc and red line. Colouring in the white arc is optional as it is not covered in PO S331.
3. Cut out a dial hand from the poster board.
4. Attach the dial hand to the centre of the representation using the brass Acco fastener.
5. Ensure that the hand can move when needed, but there is enough friction to keep them from moving on their own.

### INSTRUCTIONS – ALTIMETER

1. Draw a representation of an altimeter's face centred on the Bristol board. This will include all of the numbers and graduated lines in between the numbers. Use figures located at Annex F as guides for layout.
2. Cut dial hands from the poster board to represent the hands of an altimeter.
3. Colour in the altimeter. To add variety of colour, use yellow and black for the polygon shape under the hands pivot point.
4. Attach the hands to the centre of the altimeter representation using the brass Acco fastener.
5. Ensure that the hands can move when needed, but there is enough friction to keep them from moving on their own.

### INSTRUCTIONS – VSI

1. Draw a representation of a VSI centred on the Bristol board. This will include all of the numbers on the positive and negative scales. Ensure that zero is located on the left side. Use the figures located in Annex G as guides for layout.
2. Colour in the VSI.
3. Cut out a dial hand from poster board and attach it to the centre of the representation using the brass Acco fastener.
4. Ensure that the hand can move when needed, but there is enough friction to keep it from moving on its own.

THIS PAGE INTENTIONALLY LEFT BLANK

## TRIVIAL PURSUIT QUESTIONS

These are suggested questions that can be used for the Trivial Pursuit game in TP 5. The instructor is able to modify this list in any way. When asking a question, first set the specific training aid to the desired reading. Then allow the team whose turn it is to provide an answer. Be sure to rotate instruments every question.

### ASI QUESTIONS

For each question, set the ASI training aid to the desired value. These can be asked in any order desired.

1. 125 KIAS
2. 65 KIAS
3. 40 KIAS
4. 50 KIAS
5. 75 KIAS
6. 180 KIAS
7. 210 KIAS
8. 98 KIAS
9. 110 KIAS
10. 55 KIAS

### ALTIMETER QUESTIONS

For each question, set the altimeter training aid to the desired value. These can be asked in any order desired.

1. 8 900 feet ASL
2. 1 300 feet ASL
3. 2 600 feet ASL
4. 11 000 feet ASL
5. 7 500 feet ASL
6. 1 250 feet ASL
7. 600 feet ASL
8. 400 feet ASL
9. 300 feet ASL
10. 1 000 feet ASL

### VSI QUESTIONS

For each question, set the VSI training aid to the desired value. These can be asked in any order desired.

1. +200 feet per minute
2. +300 feet per minute

3. +150 feet per minute
4. +500 feet per minute
5. +800 feet per minute
6. -1 000 feet per minute
7. -250 feet per minute
8. -400 feet per minute
9. -900 feet per minute
10. -1 200 feet per minute

## LOCATION OF ANTI-TORQUE ROTOR



*Airforce Imagery, 2008, CH-149 Cyclone. Copyright 2006 by Sikorsky Aircraft Corporation.  
Retrieved April 9, 2008, from [http://www.airforceimagery.forces.gc.ca/netpub/server.np?find&catalog=casimages&template=detail2\\_e.np&field=itemid&op=matches&value=3018&site=casimages](http://www.airforceimagery.forces.gc.ca/netpub/server.np?find&catalog=casimages&template=detail2_e.np&field=itemid&op=matches&value=3018&site=casimages)*

Figure 12L-1 Location of Anti-Torque Rotor

THIS PAGE INTENTIONALLY LEFT BLANK

## HELICOPTER CONTROL INPUTS

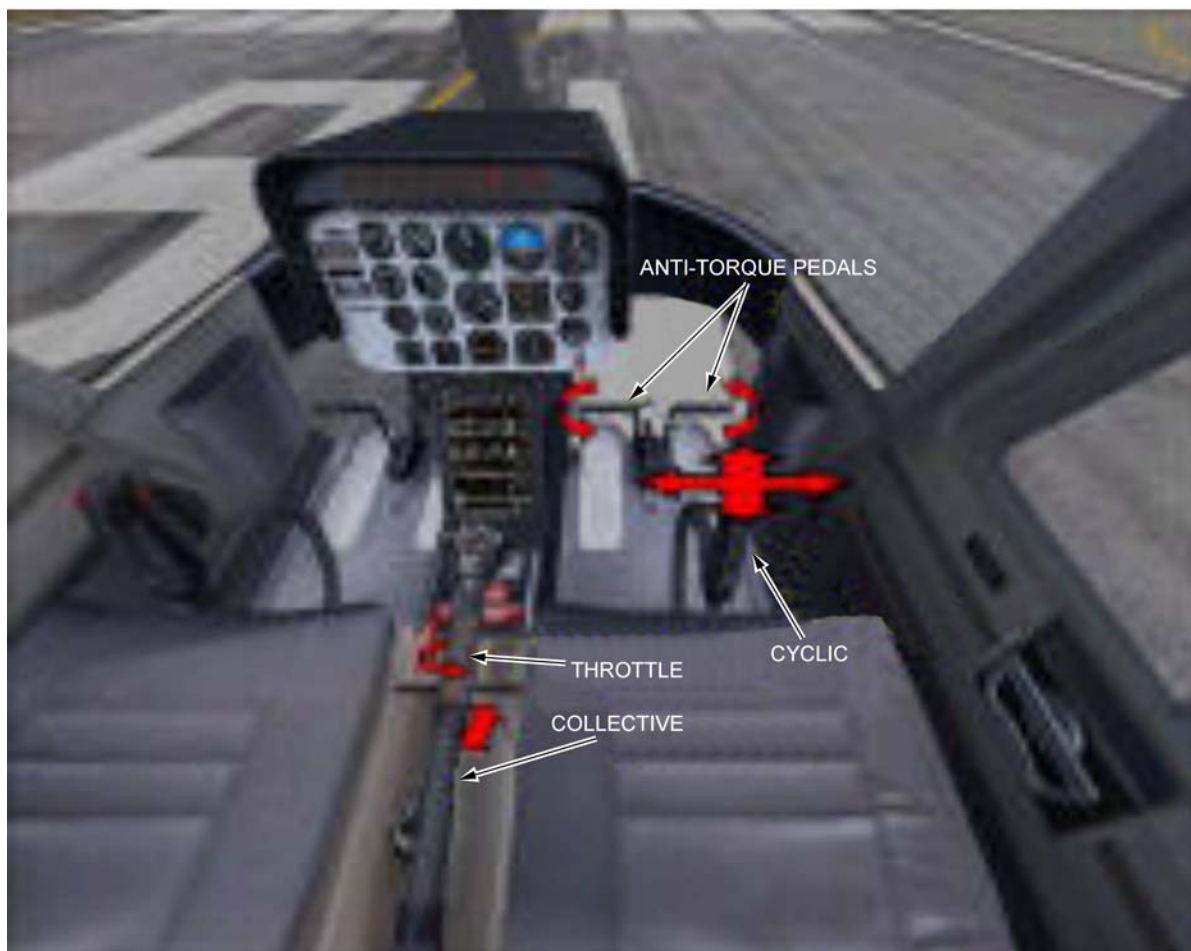

*AVSIM Online, by S. Cartwright, 2004, Helicopter Tutorial, Copyright 2004 by AVSIM Online. Retrieved April 8, 2008, from <http://www.avsim.com/pages/0604/heli/helitutorial.htm>*

Figure 12M-1 Helicopter Control Inputs

THIS PAGE INTENTIONALLY LEFT BLANK